

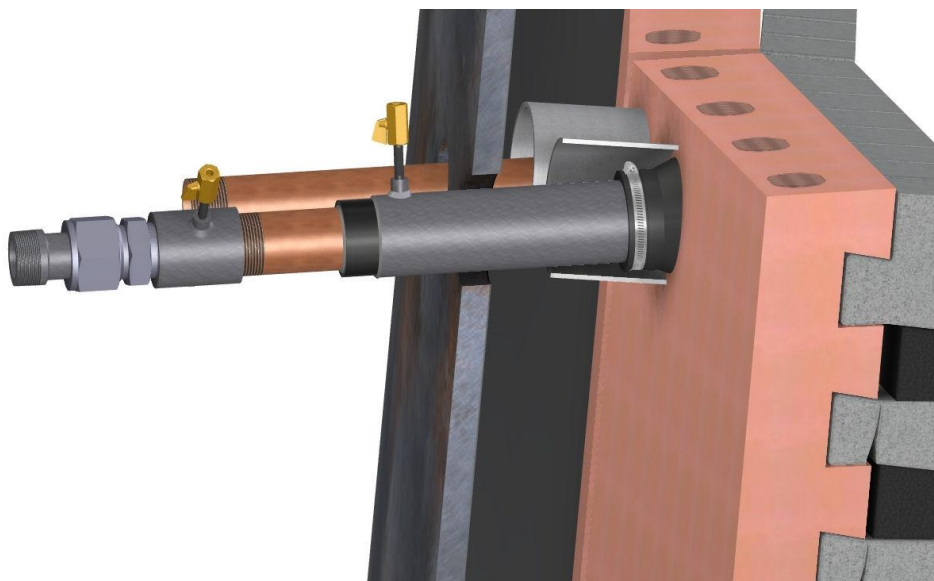

## Copper Stave Water Pipe and Plug Weld Repair System

(Patent Pending)



**Repair the failures of traditional drilled and plugged stave systems**

Weld washing and cracks



**Plug Welds**

Weld failure

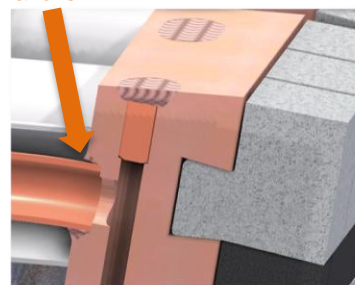

**Pipe Welds**

### Repair System Advantages

- Proven to outlast other repair methods and prevent additional circuit failures.
- When failed circuits are detected an immediate repair can be made to prevent further damage and prolong stove life. Can be installed in as little as 4 hours.
- Reestablishes water cooling directly to copper surfaces.
- Adds reinforcement to compromised inlets and can be piped using existing water hoses with minimal impact on pressure drop.
- If the repair system fails after use, it will accommodate a corrugated hose and grout secondary repair.

### Support and Services

- Custom designs to fit your stove application.
- Root cause analysis to prevent further failures and identify other areas for improvement.
- On site support during installations.
- On site or remote training to prepare for emergency installations.
- Programs available for emergency repairs.



**Packaged Repair System**



## ADVANCED IRONMAKING TECHNOLOGY

For more information on this and other technological innovations made available through our partnering agreements, contact Berry Metal Company at: 724-452-8040 or [info@berrymetal.com](mailto:info@berrymetal.com)

